

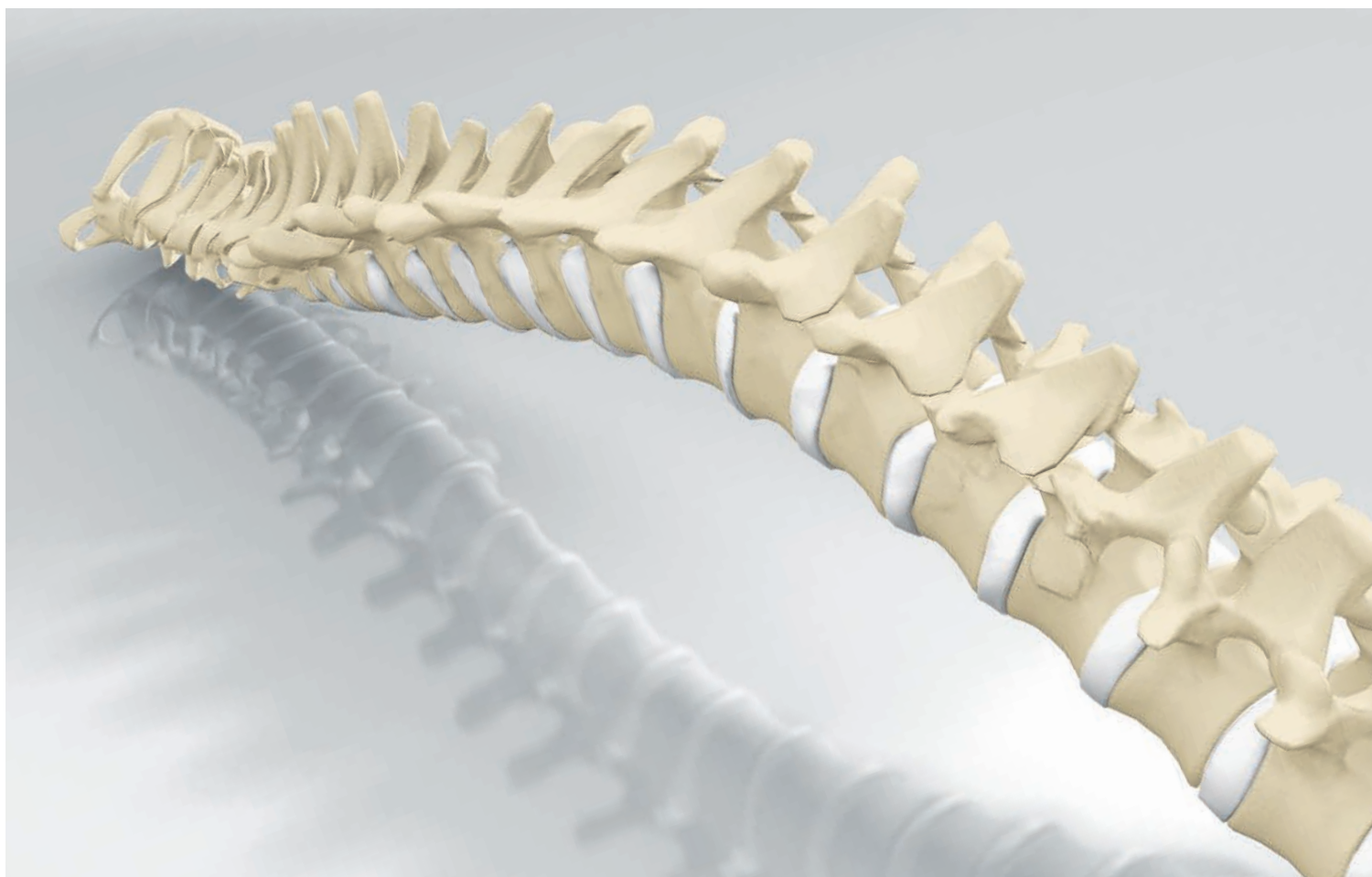

SPINE SURGERY

**AESCULAP<sup>®</sup> TSPACE<sup>®</sup> 3D**  
**TRANSFORAMINAL INTERBODY FUSION SYSTEM**  
SURGICAL MANUAL

# AESCULAP® LUMBAR SPINE



Please scan QR code or visit [www.aesculap.com](http://www.aesculap.com)  
to view full product portfolio

# AESCULAP® TSPACE® 3D

## CONTENT



<b>A</b>	<b>IMPLANT MATERIAL</b>	<b>4</b>
<b>B</b>	<b>INTENDED USE &amp; IMPLANT DESIGN</b>	<b>7</b>
<b>C</b>	<b>SURGICAL TECHNIQUE</b>	<b>8</b>
C.01.	PATIENT POSITIONING	8
C.02.	EXPOSURE OF THE INTERVERTEBRAL SPACE	8
C.03.	RESTORATION OF DISC HEIGHT	9
C.04.	DISCECTOMY	9
C.05.	PREPARATION OF ENDPLATES	10
C.06.	IMPLANT SELECTION	10
C.07.	IMPLANT REMOVAL FROM PACKAGING	11
C.08.	FILLING OF CAGE	11
C.09.	TSPACE® 3D INSERTION	12
C.10.	TSPACE® 3D FINAL IMPLANT POSITIONING	13
C.11.	POSTERIOR STABILIZATION	15
C.12.	ASSEMBLING OF THE TSPACE® INSERTER SN705R	16
<b>D</b>	<b>IMPLANT OVERVIEW</b>	<b>20</b>
<b>E</b>	<b>INSTRUMENT OVERVIEW</b>	<b>22</b>

## PROTECTING AND PRESERVING SPINAL STABILITY

Modern lifestyle has resulted in increasing physical inactivity among people all over the world. Of the many medical problems associated with this, spinal disorders are among the most critical. This is even more significant as the spinal column is one of the most important structures in the human body.

It supports and stabilizes the upper body and is the center of our musculoskeletal system, which gives the body movement. Our work in the field of spine surgery is dedicated to protecting the spinal column and preserving its stability. We support spine surgeons with durable, reliable products and partner services for reliable procedures and good clinical outcomes (1-7).

Our philosophy of sharing expertise with healthcare professionals and patients allows us to develop innovative implant and instrument systems that help to preserve stability and stabilize the cervical and thoracolumbar spine.

# AESFULAP® TSPACE® 3D

## A. IMPLANT MATERIAL

### THE TECHNOLOGY OF LASER SINTERING – A WELL-ESTABLISHED ADDITIVE LAYER BY LAYER PROCESS

■ Additive manufacturing – 3D printing – means a layer by layer process to design a device using laser beam and metal powder. This innovative laser beam melting technology is of growing importance in the manufacture of implants, as it allows to create various fine and porous surface structures with the aim to support bone-ingrowth. Homogenous or heterogeneous lattice structures or combinations of various kinds of structures and surfaces are generally conceivable.

- Direct assembly of the component based on 3D-CAD data
- Design freedom

We combined our long-time experience in designing and manufacturing spinal implants with latest technology and produce in-house our AESFULAP® 3D Cages (Fig. 1).

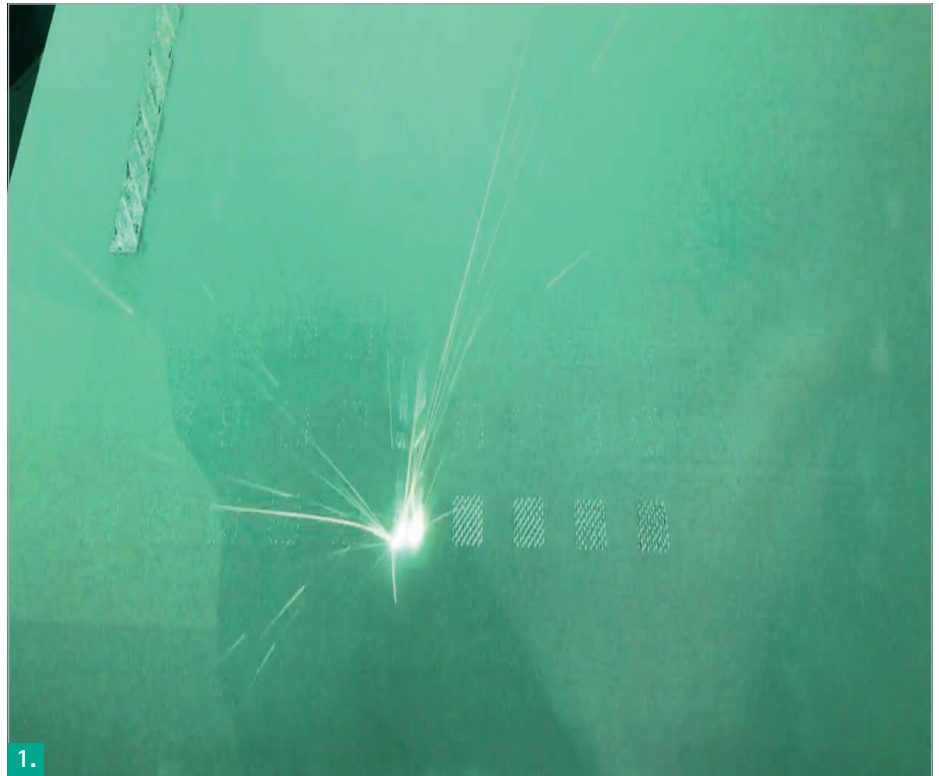

Laser beam melting technology

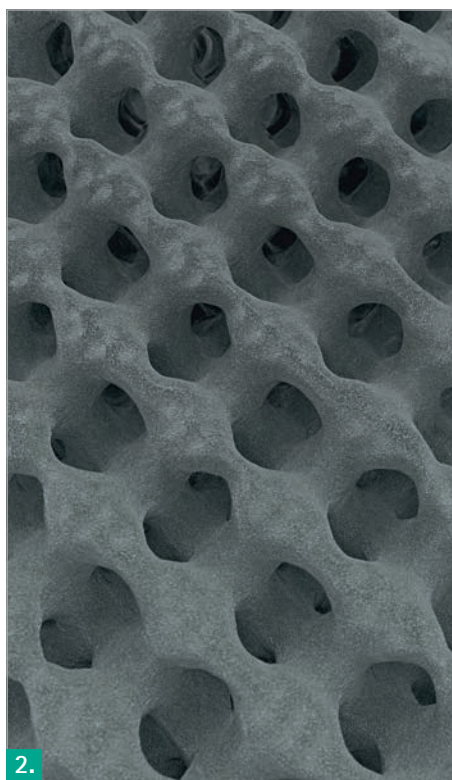

2. Lattice structure Structan®

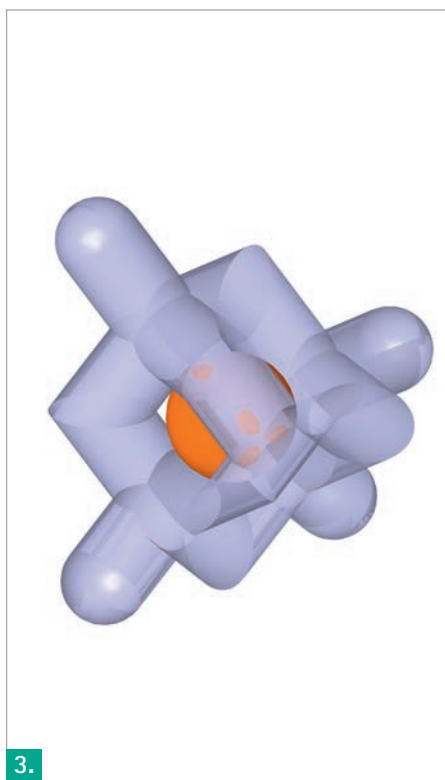

3. Unit cell with fitted ball of 900 µm

AESCULAP® 3D Cages are engineered from Structan® – a lattice structure with largely isotropic behavior. Ti6Al4V ELI was chosen as a proven and biocompatible material for implants (8).

### MORE CONNECTION

■ The lattice structure of the AESCULAP® 3D Cages shows an interconnected pore structure (Fig. 2/3). This interconnectivity facilitates migration of bone cells into the structure, thereby providing secondary stability (9, 10).

■ According to the average pore size and porosity of cancellous bone (approximately 1 mm/50-90% (11)) the 3D lattice structure Structan® features an all-over regular pore size of 900 µm as well as a mean interconnected porosity of 50-55%. Pore size and porosity are in a favorable range to stimulate bone in-growth (12, 13).

■ The results of a sheep study with partly loaded implants confirm bone growth on and into the 3D lattice structure without connective tissue layer six months post-operatively. This formation of bone tissue within the 3D lattice structure leads to a high secondary stability (10). The 3D lattice structure serves as a guide rail for bony integration and thus contributes significantly to the secure anchoring of the 3D Cage (Fig. 4).

■ A rough laser sintered surface provides a good interaction between bone cells and implant surface compared to a milled smooth surface and therefore intends to optimize osseointegration (14).

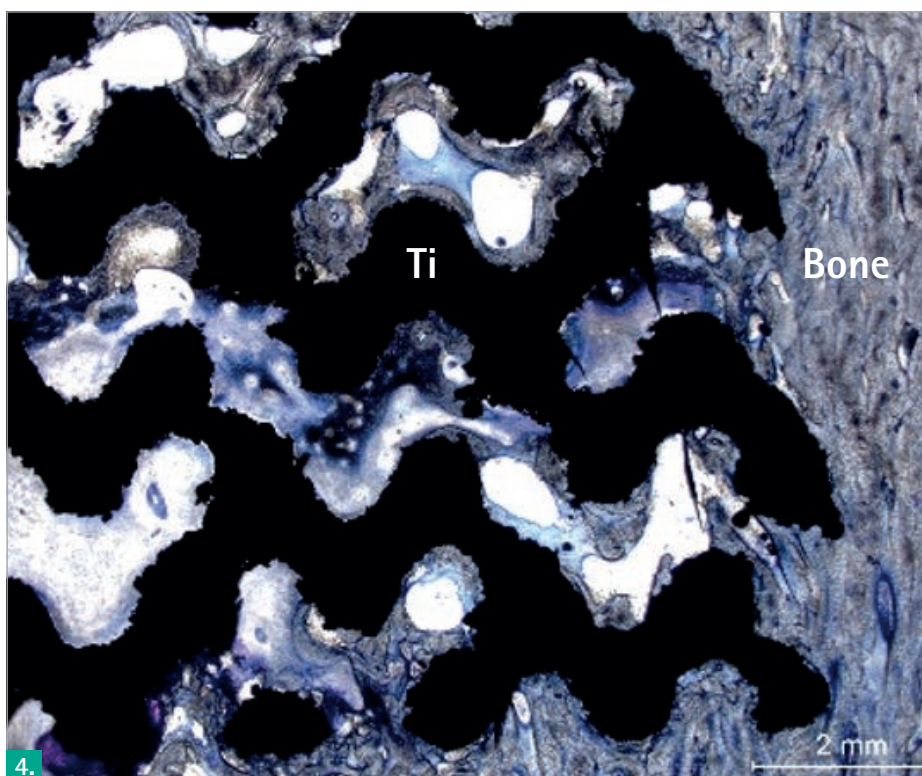

4. Histological section of the 3D Cage lattice structure filled with newly formed bone

# AESCULAP® TSPACE® 3D

## A. IMPLANT MATERIAL

### MORE ELASTICITY

Ti6Al4V ELI as solid material has a Young's modulus of approximately 110 GPa as it is shown in the figure, whereas cortical bone has a Young's modulus of approximately 5 GPa (15, 16). The Young's modulus of Structan® is developed to be close to that of cortical bone (17). This may prevent subsidence into the vertebral body (18). In addition, this may result in improved bone growth (19) (Fig. 1).

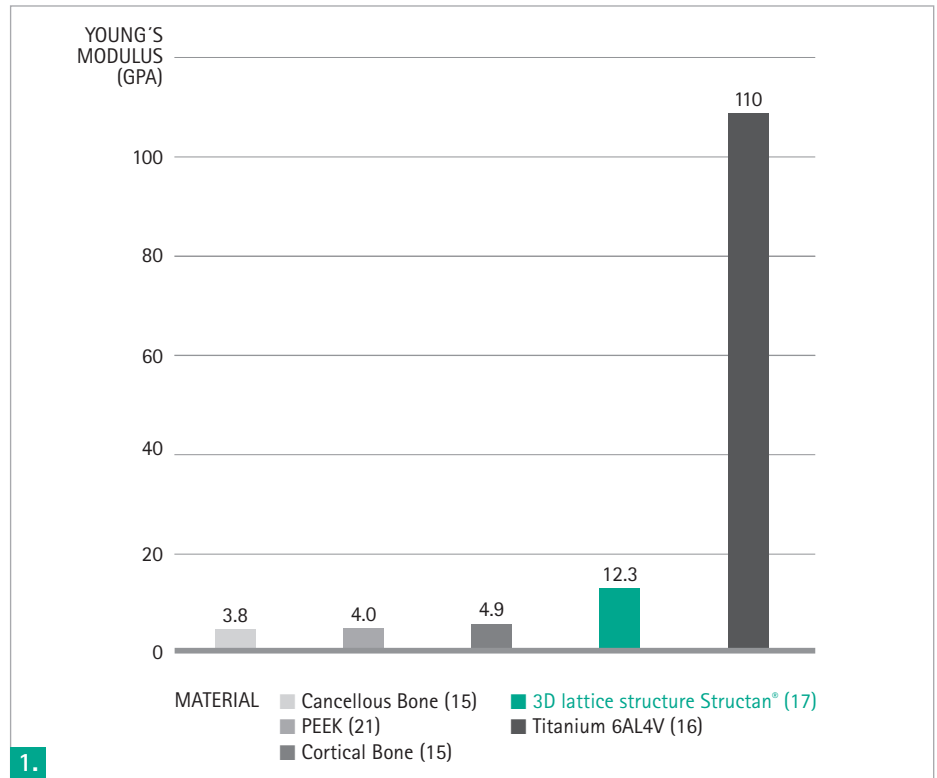

1.

Young's modulus of various materials

### MORE STRENGTH

The 3D lattice structure Structan® combines a bone-like Young's modulus with a high compressive strength, which contributes to high safety against failure due to breakage.

The compressive strength of the 3D lattice structure Structan® is higher than the mean strength of bone and PEEK (20-22) (Fig. 2).

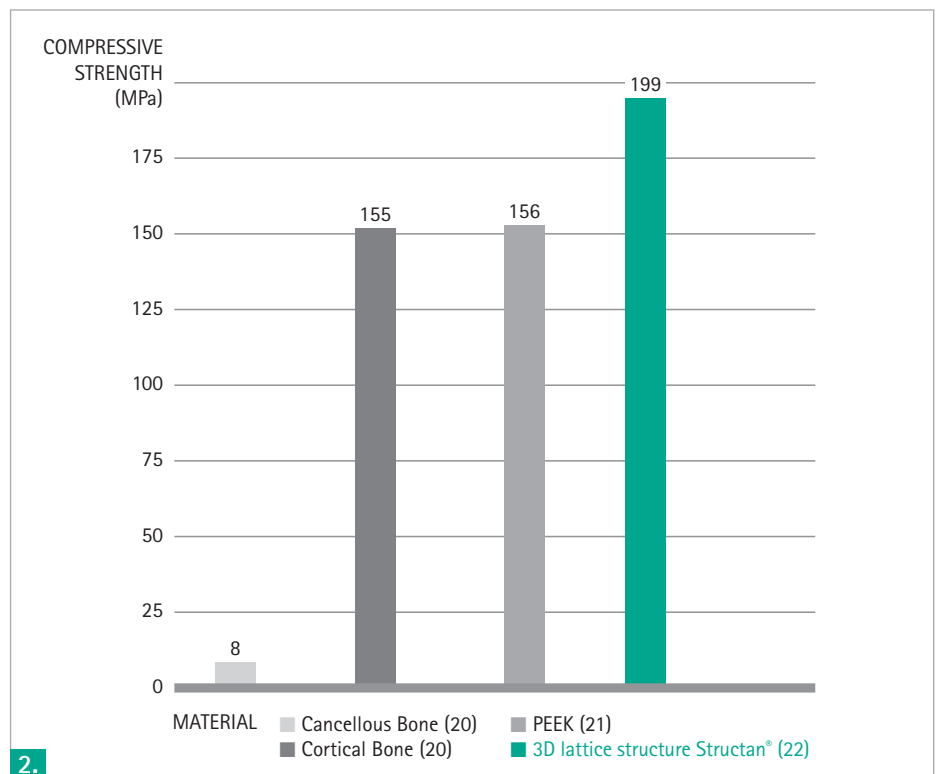

2.

Compressive strength of 3D lattice structure Structan®

## B. INTENDED USE & IMPLANT DESIGN

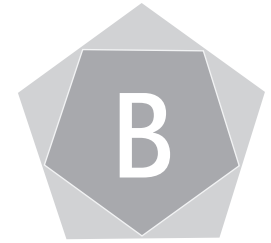

- Stabilization of the lumbar and thoracic spine through transforaminal approach, monosegmental and multisegmental.
- Always use TSPACE® 3D in conjunction with an internal fixator.
- TSPACE® 3D can be implanted through an open or minimally invasive transforaminal access.

- Solid frame without sharp edges for biomechanical stability and smooth insertion into the disc space minimizing the risk to injure surrounding soft tissue.
- Open porous structure designed to provide primary and secondary stability.
- The implant's anatomical endplate design provides a good contact area between implant and vertebral endplates whilst allowing addition of bone material to enable bone growth through the center of the implant.
- Bulleted nose for smooth insertion into the disc space.
- The articulating interface allows a firm connection to the inserter until the final implant positioning is achieved, thus enabling a controlled insertion.
- Good visibility in X-ray to localize implant positioning (23, 24).

# AESCULAP® TSPACE® 3D

## C. SURGICAL TECHNIQUE

### C.01. PATIENT POSITIONING

- The patient is positioned in the prone position for transforaminal interbody fusion with supplemental fixation (Fig. 1).
- The TLIF technique describes the unilateral insertion of a single implant through a transforaminal approach.
- TSPACE® 3D can be implanted through an open or minimally invasive access.

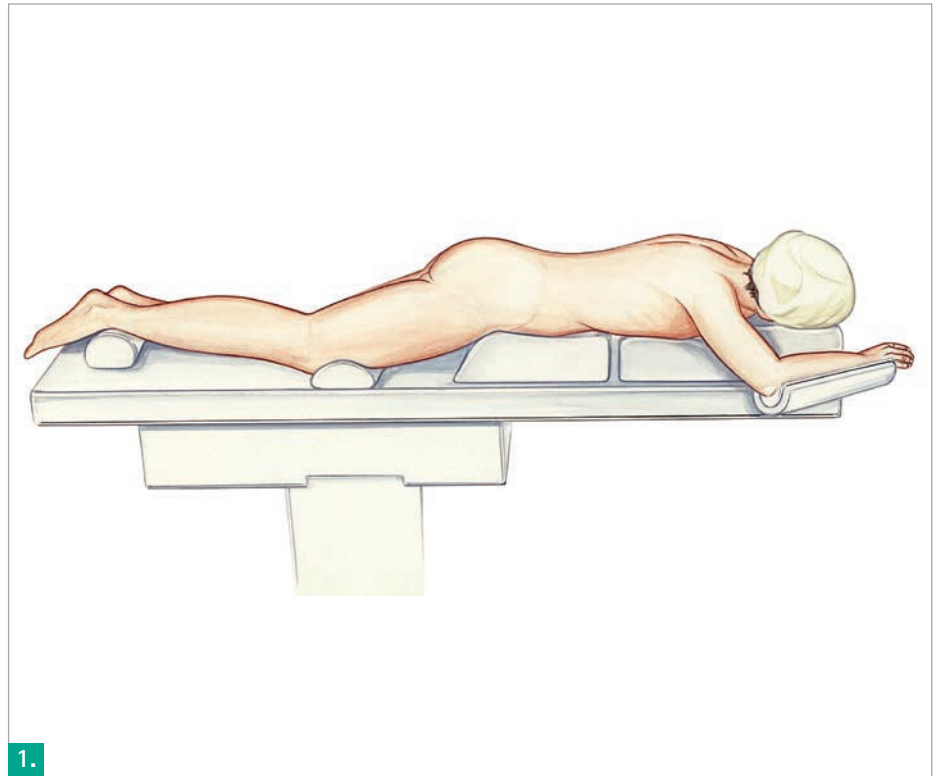

### C.02. EXPOSURE OF THE INTERVERTEBRAL SPACE

- Using an osteotome and a Kerrison bone punch the bone resection is performed to get access to the disc space. For a transforaminal approach to the disc the facet joint is resected on the side targeted for the implant insertion. The inferior articular process of the facet joint is resected first, then the subjacent superior articular process is resected (Fig. 2/3).
- In order to make room for the insertion of the distractor, resection of disc material is carried out using rongeurs and forceps.

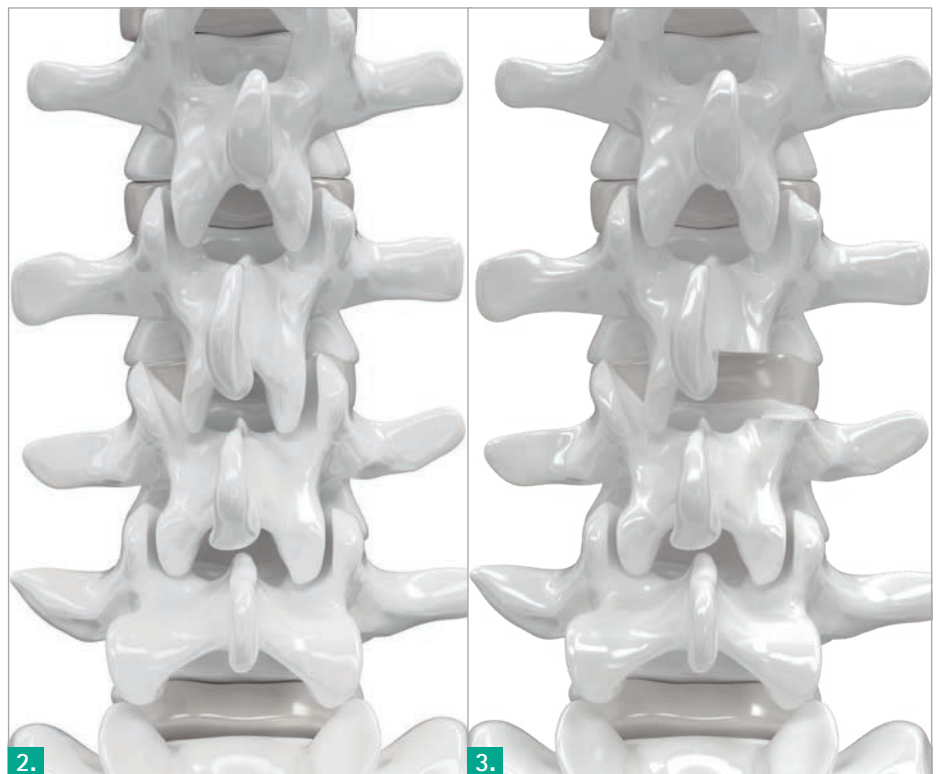

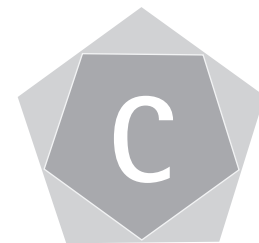

### C.03. RESTORATION OF DISC HEIGHT

- The desired distraction can be set using the distractors, available in heights from 7 - 15 mm in 1 mm increments.
- Starting with the smallest height, the distractor must be inserted horizontally and then rotated clockwise (Fig. 4).
- Rotate clockwise for a blunt height restoration maneuver. Rotate counter-clockwise to remove disc material with the built-in sharp rim.
- The distractors are inserted one after the other until the desired distraction is obtained.

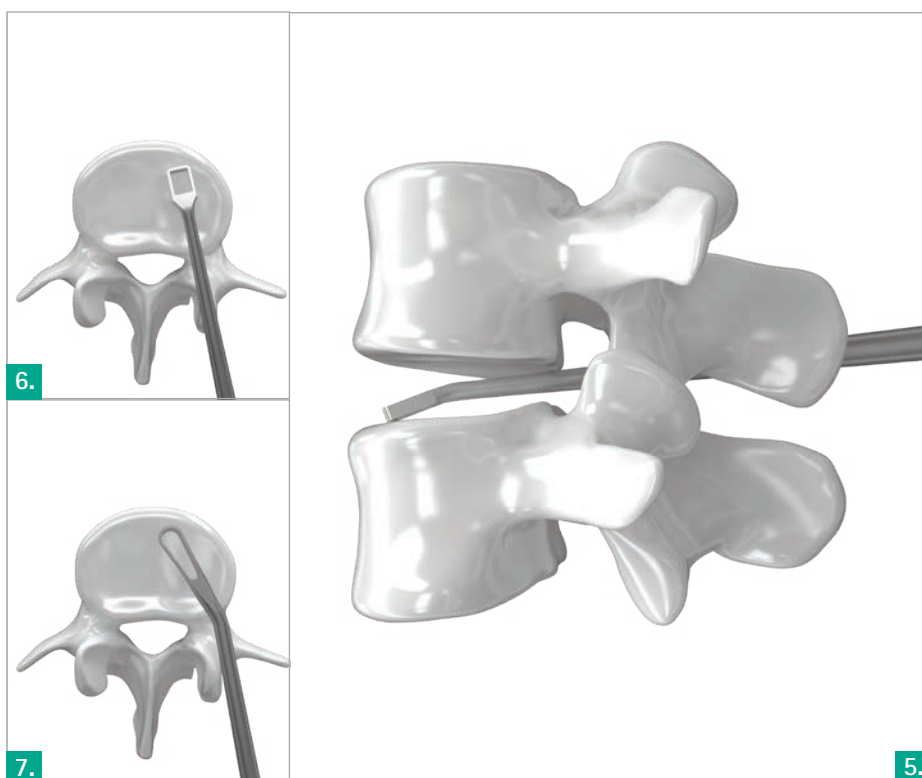

### C.04. DISCECTOMY

- The disc space is cleared using various rongeurs and curettes. The right- and left-angled curettes facilitate removal of cartilaginous material in the far lateral disc space (Fig. 5/6/7).

# AESCULAP® TSPACE® 3D

## C. SURGICAL TECHNIQUE

### C.05. PREPARATION OF ENDPLATES

- The bone rasps are used to refresh the cartilaginous endplates (Fig. 1).

#### INFORMATION

Make certain that the endplates of the neighboring vertebral bodies are not weakened, in order to minimize the risk of migration.

Make certain that the implant bed is properly prepared to avoid damage to the implant when it is driven in.



### C.06. IMPLANT SELECTION

- Use the inserter to insert the trial implant until the final end position.

#### INFORMATION

It is essential to use trial implants to establish the correct implant size.

- The trial positioning is done in the same way as the implant positioning, please refer to C.09/C.10. (Fig. 2/3).

#### INFORMATION

Please refer to C.12. for a detailed assembling description of the articulating inserter.

- Start with the smallest trial size. Step-wise the next heights are inserted until the required distraction is achieved.
- Use X-ray control to verify trial implant positioning.



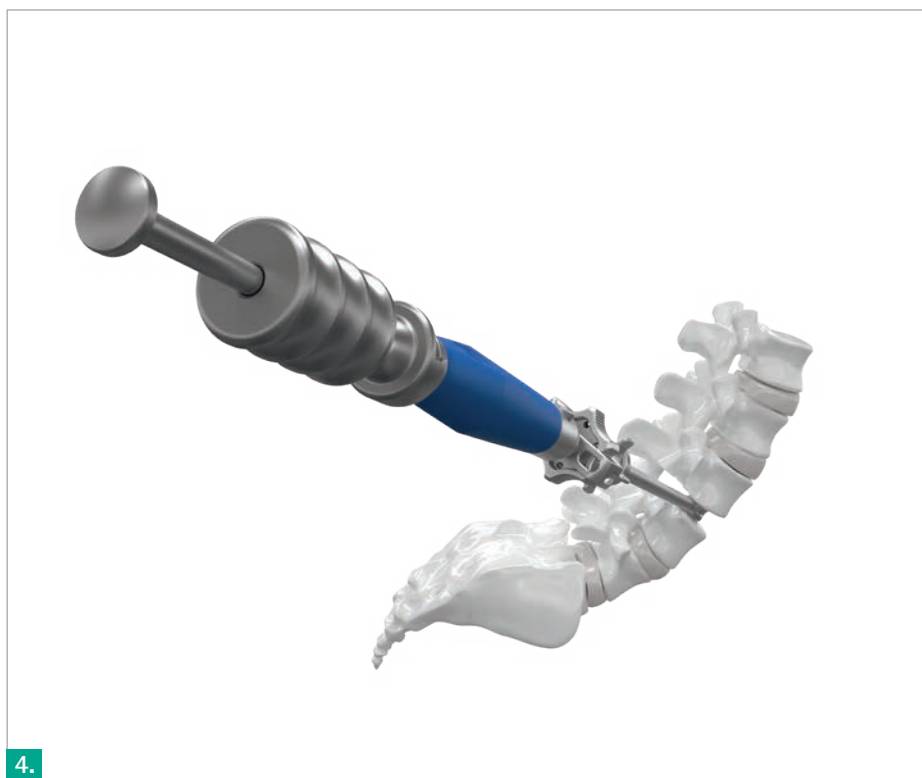
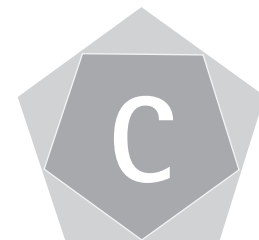

#### INFORMATION

The trials are essential to ensure the correct implant size to be used.

- Connect the slap hammer to the handle of the inserter (Fig. 4).
- Use the slap hammer to back out the trial carefully.

#### C.07. IMPLANT REMOVAL FROM PACKAGING

- Open folder blister to remove the TSPACE® 3D implant.
- The packaging concept allows implant removal with the connected inserter.

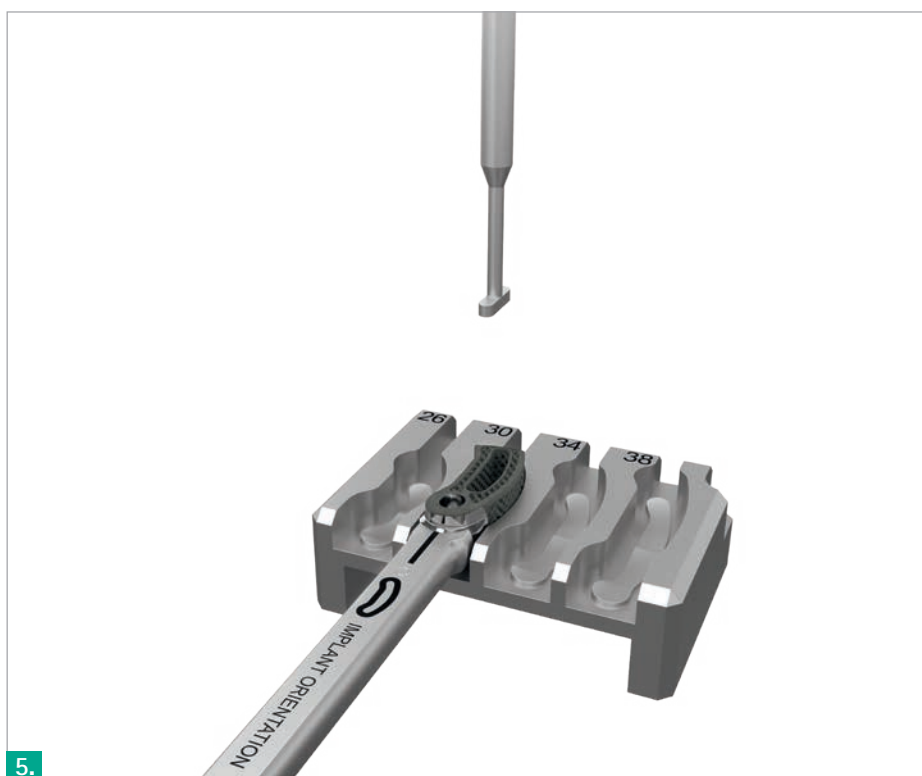

#### C.08. FILLING OF CAGE

- Use the packing block and the punch for optional filling of the implant with bone or bone substitute (Fig. 5).

#### INFORMATION

Do not use force during filling to avoid implant damaging.

# AESCULAP® TSPACE® 3D

## C. SURGICAL TECHNIQUE

### C.09. TSPACE® 3D INSERTION

- It is recommended to place bone graft in the anterior part.
- Mount the TSPACE® 3D implant along the axis of the instrument (Fig. 1).
- Ensure that the tip of the insertion rod is in horizontal position to connect the implant with the inserter. At this point, the marking shows plug lock open and rotation stop at 90° (Fig. 2).
- Turn the big rotary wheel next to the handle until the marking shows plug lock is closed. Now the implant is firmly hold (Fig. 3/4).
- Bring rotation stop to 0° position to block the rotation during initial insertion (Fig. 4).
- Recheck the connection between the implant (and respectively trial implant C.06.) and the inserter.

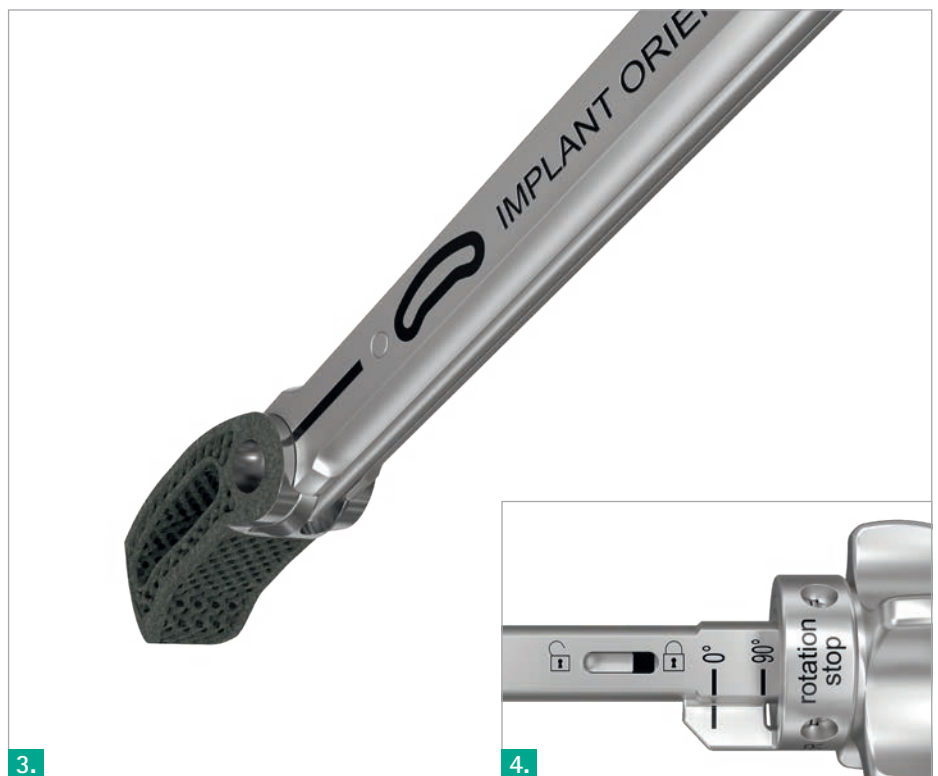
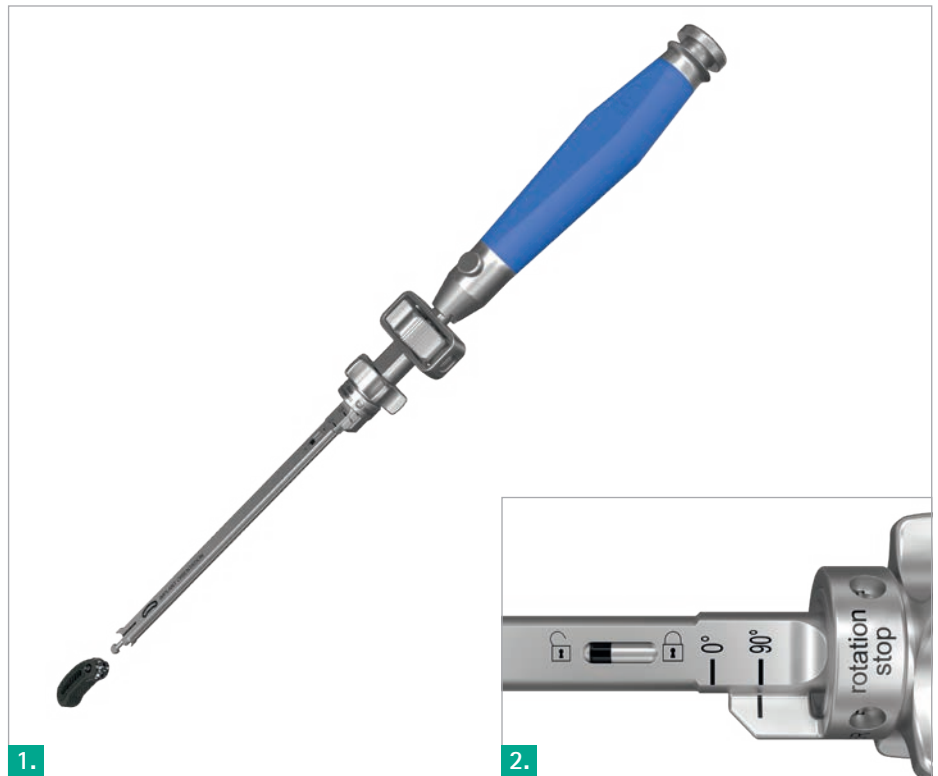

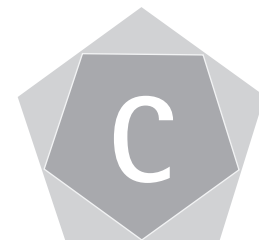

■ The TSPACE® 3D implant is introduced straight into the intervertebral space by gentle hammering on the intended surface of the handle (Fig. 5).

■ Use the nerve root retractors to protect the dura during insertion.

#### C.10. TSPACE® 3D FINAL IMPLANT POSITIONING



■ Slightly turn the big rotary wheel counterclockwise to release the preload. Therefore turn the big rotary knob just one thumb movement in counterclockwise direction, i.e. approx. up to the frame.

■ Pulling back the stop rod to 90° by turning the union nut allows a rotation maneuver of the implant.

■ Carefully hammer in the implant until it reaches the final position required. When hammering in to further advance the cage into the disc space ensure that the big rotary knob is still sufficiently tightened.

■ Alternatively, stepwise pull out the stop rod by turning the union nut (rotation range is between 0° and 90°) and further hit the implant with the mallet until it reaches the stop. Repeat until the final position is reached. If rotation maneuver is done stepwise, recheck the tension of the big rotary wheel. (Fig. 6/7).

# AESCULAP® TSPACE® 3D

## C. SURGICAL TECHNIQUE

■ Intra-operative X-ray control to verify the implant positioning (Fig. 1).

■ After the final positioning release the implant and remove the inserter by turning the big rotary wheel until the marking shows plug lock is open (Fig. 2).

### INFORMATION

Ensure not to turn further than "plug lock open" and that the black bar marking is still visible in the shaft window.

■ It is recommended to put bone material harvested from the facet joint around the TSPACE® 3D implant.

### INFORMATION

Carefully pull the inserter out of the implant. Avoid tilting of the instrument.



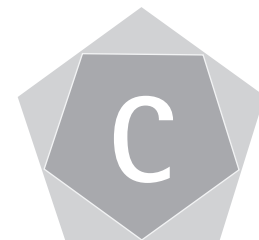

### C.11. POSTERIOR STABILIZATION

- Additional posterior stabilization of the motion segment using AEscULAP® Ennovate® Open Module (surgical technique 048102) or AEscULAP® Ennovate® MIS Module (surgical technique 000702) should be performed (Fig. 3).
- Subsequent segmental compression with posterior instrumentation allows loading of the anterior column and restoration of sagittal alignment.
- Final X-ray.

# AESCULAP® TSPACE® 3D

## C. SURGICAL TECHNIQUE

### C.12. ASSEMBLING OF THE TSPACE® INSERTER SN705R

The inserter consists of three parts and the handle (Fig. 1).

- 1 Shaft
- 1a Rotary wheel
- 2 Bayonet rod
- 3 Rotation stop with stop rod
- 3a Union nut

#### INFORMATION

Please consider regular oiling.

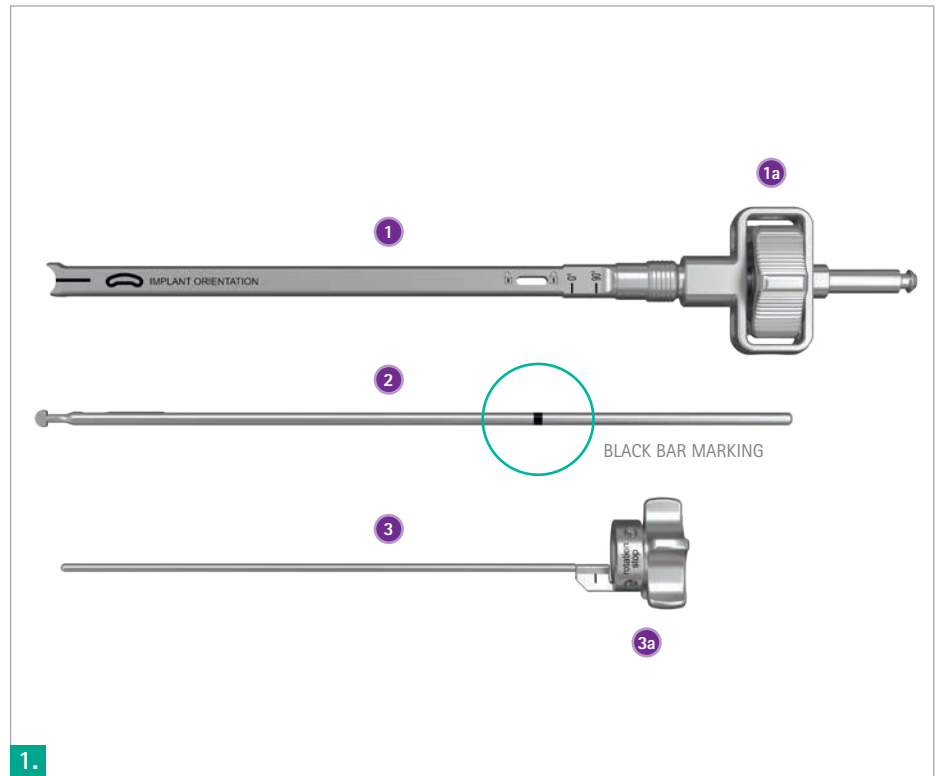

To assemble the inserter first put the bayonet rod 2 in the shaft 1 up to the stop. Markings on the shaft and the bayonet rod (line to line) have to be observed (Fig. 2).

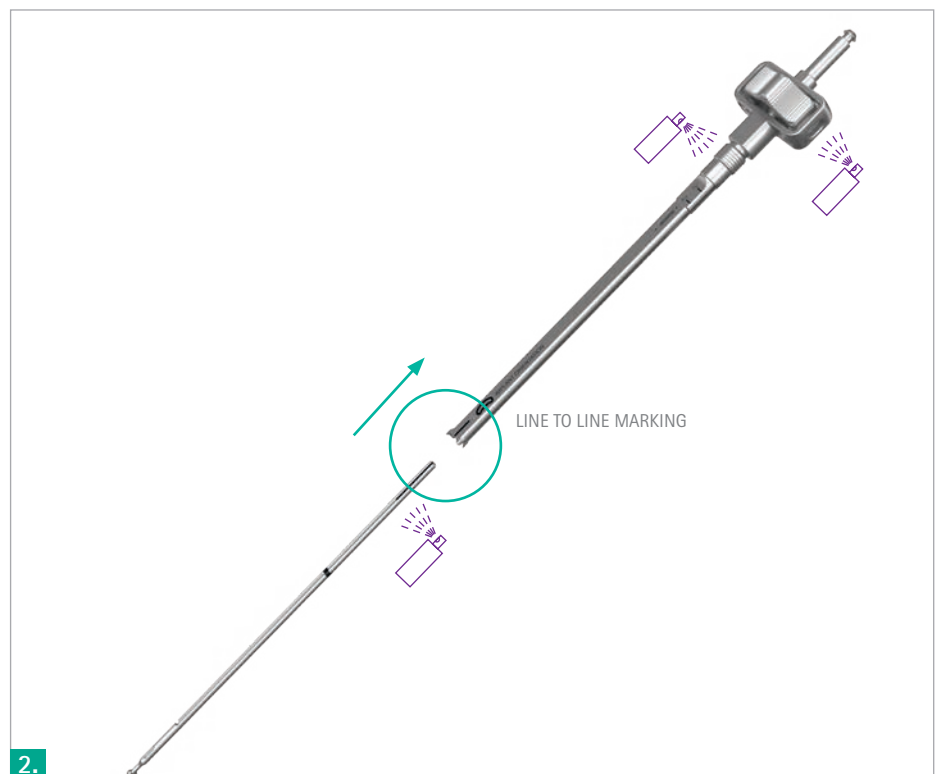

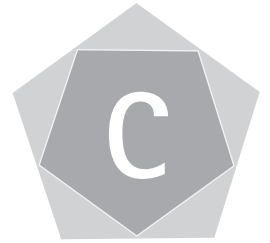

After the stop is achieved (Fig. 3) turn bayonet rod 90° and push it further in shaft 1.

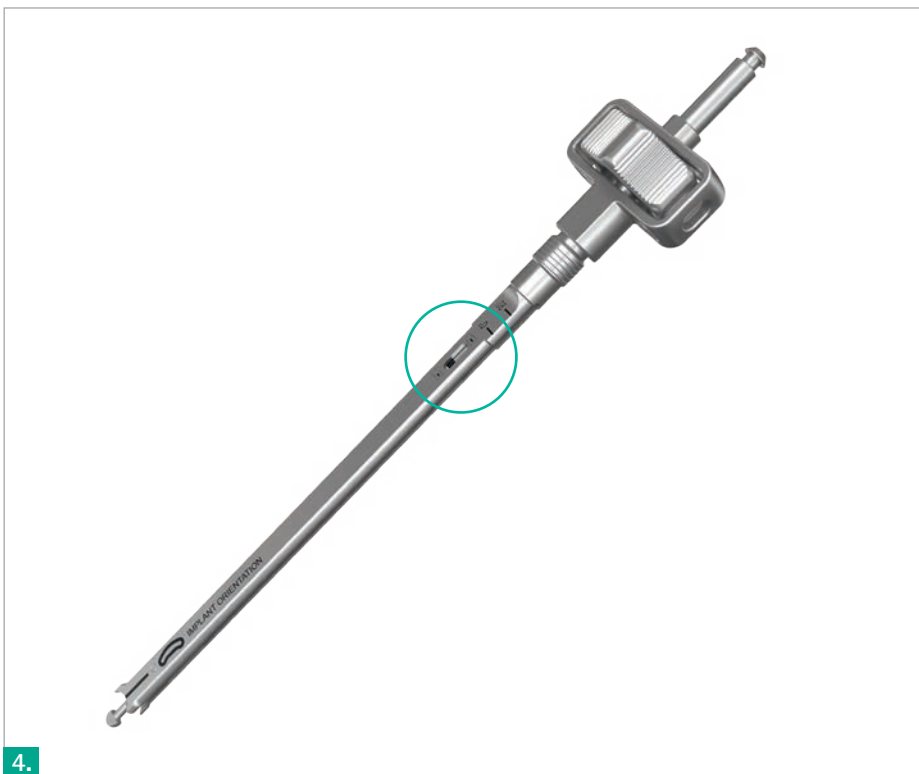

Turn rotary wheel 1a in clockwise direction until the black bar marking of the bayonet rod 2 is visible in the window (Fig. 4).

# AESCULAP® TSPACE® 3D

## C. SURGICAL TECHNIQUE

- Put the rotation stop 3 in the lateral slot of shaft 1 and push it until the threads (Fig. 1).

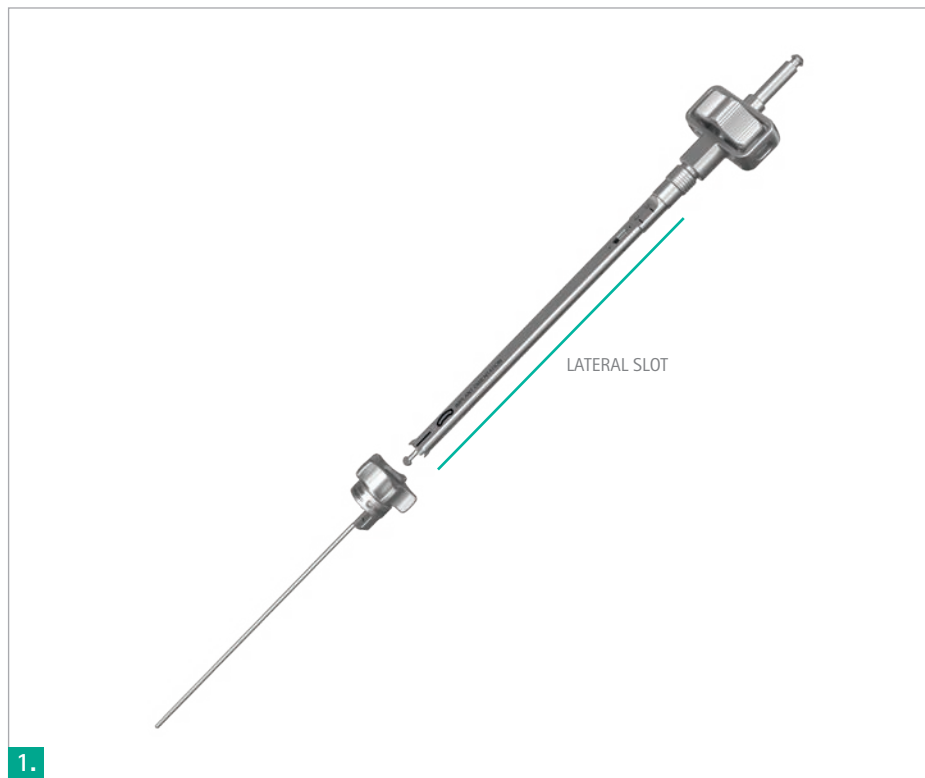

- Turn the union nut 3a in counterclockwise direction up to the stop (Fig. 2).



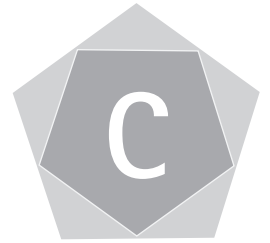

■ Attach handle S0505R to the inserter (Fig. 3 / 4).

■ The handle offers the possibility to attach the slap hammer extension SN320R for trial removal.



# AESCALAP<sup>®</sup> TSPACE<sup>®</sup> 3D

## D. IMPLANT OVERVIEW

LORDOSIS 5°



Nominal height

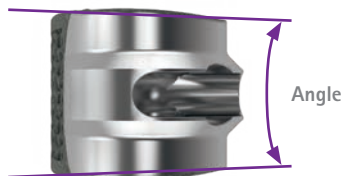

Article No.	Size (Height x Width x Length)	Quantity
SN707T	7 x 11.5 x 26 mm	2
SN708T	8 x 11.5 x 26 mm	2
SN709T	9 x 11.5 x 26 mm	2
SN710T	10 x 11.5 x 26 mm	2
SN711T	11 x 11.5 x 26 mm	2
SN712T	12 x 11.5 x 26 mm	2
SN713T	13 x 11.5 x 26 mm	2
SN715T	15 x 11.5 x 26 mm	2
SN727T	7 x 11.5 x 30 mm	2
SN728T	8 x 11.5 x 30 mm	2
SN729T	9 x 11.5 x 30 mm	2
SN730T	10 x 11.5 x 30 mm	2
SN731T	11 x 11.5 x 30 mm	2
SN732T	12 x 11.5 x 30 mm	2
SN733T	13 x 11.5 x 30 mm	2
SN735T	15 x 11.5 x 30 mm	2







<b>Article No.</b>	<b>Size (Height x Width x Length)</b>	<b>Quantity</b>
SN748T	8 x 11.5 x 34 mm	2
SN749T	9 x 11.5 x 34 mm	2
SN750T	10 x 11.5 x 34 mm	2
SN751T	11 x 11.5 x 34 mm	2
SN752T	12 x 11.5 x 34 mm	2
SN753T	13 x 11.5 x 34 mm	2
SN755T	15 x 11.5 x 34 mm	2
SN768T	8 x 11.5 x 38 mm	2
SN769T	9 x 11.5 x 38 mm	2
SN770T	10 x 11.5 x 38 mm	2
SN771T	11 x 11.5 x 38 mm	2
SN772T	12 x 11.5 x 38 mm	2
SN773T	13 x 11.5 x 38 mm	2
SN775T	15 x 11.5 x 38 mm	2





# AESCULAP® TSPACE® 3D

## E. INSTRUMENT OVERVIEW

### SN505 PREPARATION INSTRUMENTS – LUMBAR PREPARATION CLEANING DISC SPACE

	Article No.	Description	Quantity
	SN506R	Tray lumbar prep. 3D Cages discectomy	1
	TF356	Packing stencil f/SN506R (SN505)	1
	JA455R	Lid for OrthoTray DIN w/o handle	1
	FJ658R	Osteotome	1
	FL045R	Mallet	1
	FJ051R	Retractor S	1
	FJ052R	Retractor M	1
	FJ053R	Retractor L	1
	FJ054R	Retractor XL	1
	SJ883R	Box curette straight	1
	SJ885R	Teardrop curette large	1



	Article No.	Description	Quantity
	FJ682R*	Curette 45° Lt. ang	1
	FJ683R*	Curette 45° rt. ang	1
	SJ882R	Bone curette straight	1
	FJ679R*	Bone curette 45° Lt. ang	1
	FJ680R*	Bone curette 45° rt. ang	1
	FJ684R	Bone rasp straight	1
	FJ685R*	Bone rasp 45° Lt. ang	1
	FJ686R*	Bone rasp 45° rt. ang	1

#### INFORMATION

\* Alternatively 20° angled

■ Currettes (FJ702R - FJ703R),



■ Bone currettes (FJ698R - FJ699R) and

■ Bone rasps (FJ704R - FJ705R) are available.

# AESCALAP<sup>®</sup> TSPACE<sup>®</sup> 3D

## E. INSTRUMENT OVERVIEW

### SN505 PREPARATION INSTRUMENTS – LUMBAR PREPARATION DISTRACTION

	Article No.	Description	Quantity
	SN507R	Tray lumbar prep. 3D Cages distraction	1
	TF357	Packing stencil f/SN507R (SN505)	1
	JA455R	Lid for OrthoTray DIN w/o handle	1
	FJ647R	Distractor 7 mm	1
	FJ648R	Distractor 8 mm	1
	FJ649R	Distractor 9 mm	1
	FJ650R	Distractor 10 mm	1
	FJ651R	Distractor 11 mm	1
	FJ652R	Distractor 12 mm	1
	FJ653R	Distractor 13 mm	1
	FJ654R	Distractor 14 mm	1
	FJ655R	Distractor 15 mm	1
	SJ033R	T-handle w/ anvil	2

#### INFORMATION

Recommended container: JK446

Recommended container lid: JK486

Recommended identification label: JG786B



## SN700 IMPLANTATION INSTRUMENTS – TSPACE® 3D IMPLANTATION

Article No.	Description	Size (Height x Width x Length)	Quantity
SN701R	TSPACE® 3D tray f/instrumentation		1
TF354	Packing stencil f/SN701R (SN700)		1
JA455R	Lid for OrthoTray DIN w/o handle		1
SN322R	TSPACE® PEEK/XP/3D trial implant 5°	7 x 11.5 x 26 mm	1
SN323R	TSPACE® PEEK/XP/3D trial implant 5°	8 x 11.5 x 26 mm	1
SN324R	TSPACE® PEEK/XP/3D trial implant 5°	9 x 11.5 x 26 mm	1
SN325R	TSPACE® PEEK/XP/3D trial implant 5°	10 x 11.5 x 26 mm	1
SN326R	TSPACE® PEEK/XP/3D trial implant 5°	11 x 11.5 x 26 mm	1
SN327R	TSPACE® PEEK/XP/3D trial implant 5°	12 x 11.5 x 26 mm	1
SN328R	TSPACE® PEEK/XP/3D trial implant 5°	13 x 11.5 x 26 mm	1
SN330R	TSPACE® PEEK/XP/3D trial implant 5°	15 x 11.5 x 26 mm	1
SN352R	TSPACE® PEEK/XP/3D trial implant 5°	7 x 11.5 x 30 mm	1
SN353R	TSPACE® PEEK/XP/3D trial implant 5°	8 x 11.5 x 30 mm	1
SN354R	TSPACE® PEEK/XP/3D trial implant 5°	9 x 11.5 x 30 mm	1
SN355R	TSPACE® PEEK/XP/3D trial implant 5°	10 x 11.5 x 30 mm	1



# AESCULAP® TSPACE® 3D



## E. INSTRUMENT OVERVIEW

### SN700 IMPLANTATION INSTRUMENTS – TSPACE® 3D IMPLANTATION

	Article No.	Description	Size (Height x Width x Length)	Quantity
	SN356R	TSPACE® PEEK/XP/3D trial implant 5°	11 x 11.5 x 30 mm	1
	SN357R	TSPACE® PEEK/XP/3D trial implant 5°	12 x 11.5 x 30 mm	1
	SN358R	TSPACE® PEEK/XP/3D trial implant 5°	13 x 11.5 x 30 mm	1
	SN360R	TSPACE® PEEK/XP/3D trial implant 5°	15 x 11.5 x 30 mm	1
	SN383R	TSPACE® PEEK/XP/3D trial implant 5°	8 x 11.5 x 34 mm	1
	SN384R	TSPACE® PEEK/XP/3D trial implant 5°	9 x 11.5 x 34 mm	1
	SN385R	TSPACE® PEEK/XP/3D trial implant 5°	10 x 11.5 x 34 mm	1
	SN386R	TSPACE® PEEK/XP/3D trial implant 5°	11 x 11.5 x 34 mm	1
	SN387R	TSPACE® PEEK/XP/3D trial implant 5°	12 x 11.5 x 34 mm	1
	SN388R	TSPACE® PEEK/XP/3D trial implant 5°	13 x 11.5 x 34 mm	1
	SN390R	TSPACE® PEEK/XP/3D trial implant 5°	15 x 11.5 x 34 mm	1
	SN783R	TSPACE® 3D trial implant 5°	8 x 11.5 x 38 mm	1
	SN784R	TSPACE® 3D trial implant 5°	9 x 11.5 x 38 mm	1
	SN785R	TSPACE® 3D trial implant 5°	10 x 11.5 x 38 mm	1
	SN786R	TSPACE® 3D trial implant 5°	11 x 11.5 x 38 mm	1
	SN787R	TSPACE® 3D trial implant 5°	12 x 11.5 x 38 mm	1
	SN788R	TSPACE® 3D trial implant 5°	13 x 11.5 x 38 mm	1
	SN790R	TSPACE® 3D trial implant 5°	15 x 11.5 x 38 mm	1



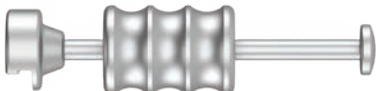
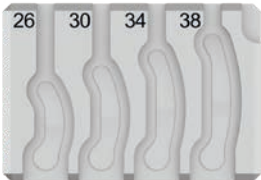

## SN700 IMPLANTATION INSTRUMENTS – TSPACE® 3D IMPLANTATION

	<b>Article No.</b>	<b>Description</b>	<b>Quantity</b>
	<b>SN320R</b>	TSPACE® PEEK/XP/3D slap hammer	1
	<b>SN704R</b>	TSPACE® 3D packing block	1
	<b>SN503R</b>	Tamper f/lumbar 3D cage systems	1

# AESCULAP® TSPACE® 3D

## E. INSTRUMENT OVERVIEW

### SN700 IMPLANTATION INSTRUMENTS – TSPACE® 3D IMPLANTATION

	Article No.	Description	Quantity
	SN705R	TSPACE® PEEK/XP/3D insertion instrument	2
	S0505R	Handle	2

#### INFORMATION

Recommended container: JK440

Recommended container lid: JK486

Recommended identification label: JG786B

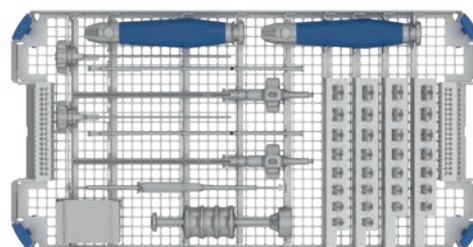
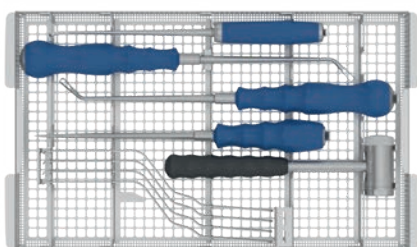
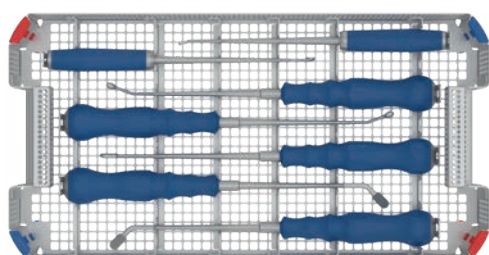

---

SN700

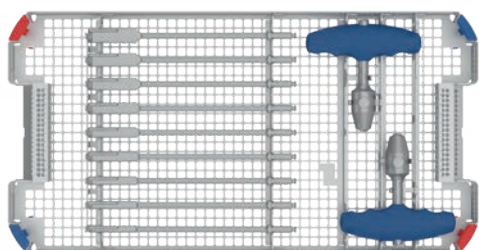

---

SN505

# AESCULAP® TSPACE® 3D

## REFERENCES

- (1) Tropiano P, Bronsard JJ, Louis C, Tallet JM, Sauget Y. Three column stabilisation through a posterior approach with a titanium PLASMAPORE® intervertebral block (PROSPACE®). Radiological and clinical study after 4 years. *Rivista di Neuroradiologia*. 1999;12(Suppl 1):89-94.
- (2) Kroppenstedt S, Gulde M, Schönmayr R. Radiological comparison of instrumented posterior lumbar interbody fusion with one or two closed-box PLASMAPORE® coated titanium cages. Follow-up study over more than seven years. *Spine*. 2008;33(19):2083-8.
- (3) Kreinest M, Schmahl D, Grützner PA, Matschke S. Radiological Results and Clinical Patient Outcome After Implantation of a Hydraulic Expandable Vertebral Body Replacement following Traumatic Vertebral Fractures in the Thoracic and Lumbar Spine: A 3-Year Follow-Up. *Spine (Phila Pa 1976)*. 2017 Apr 15;42(8):E482-E489.
- (4) Takeuchi M, Yasuda M, Niwa A, Wakao N, Nakura T, Osuka K et al. PLASMAPORE®-coated titanium cervical cages induce more rapid and complete bone fusion after anterior cervical discectomy and fusion as compared to noncoated titanium cage. *World Neurosurgery*. 2014;82(3/4):519-22.
- (5) Vanek P, Bradac O, Konopkova R, de Lacy P, Lacman J, Benes V. Treatment of thoracolumbar trauma by short-segment percutaneous transpedicular screw instrumentation: prospective comparative study with a minimum 2-year follow-up. *J Neurosurg Spine*. 2014;20:150-6.
- (6) Beisse R. Endoscopic surgery on the thoracolumbar junction of the spine. *Eur Spine J*. 2006;15:687-704.
- (7) Finger T, Bayerl S, Onken J, Czabanka M, Woitzik J, Vajkoczy P. Sacropelvic fixation versus fusion to the sacrum for spondylosis in multilevel degenerative spine disease. *Eur Spine J*. 2014;23:1013-20.
- (8) Ngoc Bich VU et al. In vitro and in vivo biocompatibility of Ti-6Al-4V titanium alloy and UHMWPE polymer for total hip replacement. *Biomedical Research and Therapy*. 2016;3(3):567-77.
- (9) Van der Stok J, Van der Jagt O, Yavari S, De Haas M, Waarsing J, Jahr H et al. Selective laser melting-produced porous titanium scaffolds regenerate bone in critical size cortical bone defects. *Journal of Orthopaedic Research*. 2013;31(5):792-9.
- (10) In vivo study of porous metallic lattice structures, Ulm, 2011. The biocompatibility, osseointegration and biomechanical properties of porous Ti6Al4V implants manufactured by SLM were tested under mechanical loading conditions in an ovine model study sponsored by Aesculap AG. The samples were evaluated histologically and biomechanically after implantation. Porous Ti6Al4V implants exhibited very good biocompatibility, bone-implant interface strength and osseointegration. Six months after implantation, bone ingrowth on and into the porous Ti6Al4V implants was reported. Inflammatory reactions that may influence bone formation were not observed.
- (11) Karageorgiou V, Kaplan D. Porosity of 3D biomaterial scaffolds and osteogenesis. *Biomaterials*. 2005;26(27):5474-91.
- (12) Taniguchi N et al. Effect of pore size on bone ingrowth into porous titanium implants fabricated by additive manufacturing: an in vivo experiment. *Materials Science and Engineering: C*. 2016;59:690-701.
- (13) Van Bael S et al. The effect of pore geometry on the in vitro biological behavior of human periosteum-derived cells seeded on selective laser-melted Ti6Al4V bone scaffolds. *Acta biomaterialia*. 2012;8(7):2824-34.
- (14) Elias CN et al. Mechanical and clinical properties of titanium and titanium-based alloys (Ti G2, Ti G4 cold worked nano structured and Ti G5) for biomedical applications. *Journal of Materials Research and Technology*. 2019;8(1):1060-9.

- (15) Kuhn JL, Goldstein SA, Choi K, London M, Feldkamp LA, Matthews LS. Comparison of the trabecular and cortical tissue moduli from human iliac crests. *J Orthop Res.* 1989;7(6):876-84.
- (16) Ratner BD, Hoffmann AS, Schoen FJ, Lemons JE. *An Introduction to Materials in Medicine.* Academic Press. 1996.
- (17) Internal Report U-0464/19: Product Qualification Validation of Aesculap 3D Cages lattice structure, Tuttlingen, 2019. In the scope of a product-related PQ validation, test specimens were manufactured with a lattice structure corresponding to the Aesculap 3D Cages. Subsequently, the strength was determined by a static compression test, the microstructure by a structural analysis as well as the dimensional accuracy by measuring the lattice struts. The investigated lattice test specimens totally satisfied the acceptance criteria in terms of lattice dimensions, strength and microstructure.
- (18) Chen Y, Wang X, Lu X, Yang L, Yang H, Yuan W et al. Comparison of titanium and polyetheretherketone (PEEK) cages in the surgical treatment of multilevel cervical spondylotic myelopathy: a prospective, randomized, control study with over 7-year follow-up. *Eur Spine J.* 2013;22(7):1539-46.
- (19) Brizuela A et al. Influence of the elastic modulus on the Osseointegration of Dental Implants. *Materials.* 2019;12(6):980.
- (20) Azami M, Moztafzadeh F, Tahriri M. Preparation, characterization and mechanical properties of controlled porous gelatin/hydroxyapatite nanocomposite through layer solvent casting combined with freeze-drying and lamination techniques. *Journal of Porous Materials.* 2010;17(3):313-20.
- (21) Rae PJ, Brown EN, Orlor EB. The mechanical properties of poly (ether-ether-ketone) (PEEK) with emphasis on the large compressive strain response. *Polymer.* 2007;48(2):598-615.
- (22) Internal Report U-0246/19: Equivalence test on 3D Cages, compressive specimens with 3D Cage lattice structure and standard tensile specimens, Tuttlingen, 2019.
- The aim of the study was to verify the equivalence of mechanical tests on both test specimens and Aesculap 3D Cages. For this purpose, test specimens and implants were built up in a single production job by using laser sintering technology and were tested afterwards. The results of the static and dynamic compression tests on lattice test specimens as well as tensile tests on tensile specimens showed a high equivalence to the results of the „Dynamic Axial Compression Test according to ASTM F2077“ on implants. The test specimens showed a well-known behavior, and all nominal or standard values were reached or exceeded.
- (23) Usability-Test, Usability Validation of AESCULAP® TSPACE® 3D Cages, Tübingen, 2019. The usability of the AESCULAP® 3D Cage System TSPACE® 3D was tested in April 2019, in a cadaver workshop with six independent test persons as intended users (surgeons specialized in spinal surgery or comparable fields). Parameters such as implant visibility under x-ray control, mechanical stability of the implant/instrument interface and implant surface evaluation in terms of tissue injury risk were tested among others. Acceptance criteria were fulfilled for all the above-mentioned parameters. All test users confirmed the absence of critical features that must be improved prior to clinical use.
- (24) Rehnitz, Christoph, PD Dr. med. Radiological image evaluation of AESCULAP® interbody fusion devices, Heidelberg, 2019. CT and X-ray visualization of different AESCULAP® interbody fusion cages (full titanium, porous Ti6Al4V and PLASMAPORE® XP cages) was tested in a cadaver setup. A radiologist evaluated the implant visibility and the presence of artefacts that may limit the visualization of adjacent structures. Visualization and assessment of implant position was achieved in X-ray and CT for all tested cages. Minor artefacts were visible in CT reconstructions in the surrounding of porous Ti6Al4V and full titanium implants. Porous Ti6Al4V implants showed slightly fewer artefacts in CT in comparison to full titanium implants. The minor artefacts observed did not limit the assessment of the surrounding anatomical structures.

# AESCULAP<sup>®</sup> – a B. Braun brand

Aesculap AG | Am Aesculap-Platz | 78532 Tuttlingen | Germany  
Phone +49 7461 95-0 | Fax +49 7461 95-2600 | [www.aesculap.com](http://www.aesculap.com)

The main product trademark "AESCULAP" and the product trademarks "Ennovate", "PLASMAPORE", "Structan" and "TSPACE" are registered trademarks of Aesculap AG.

Subject to technical changes. All rights reserved. This brochure may only be used for the exclusive purpose of obtaining information about our products. Reproduction in any form partial or otherwise is not permitted.